

GTSM Control Module

Synchronization Control Module

Applications

The Gentex GTSM synchronization control module is designed to provide an easy way to synchronize multiple horns, strobes and horn/strobes using only two wires in instances where a synchronized flash is required. When synchronizing multiple horns and horn/strobes, the GTSM has the capability to synchronize multiple horn signals with a temporal 3 pattern, a temporal 4 pattern and the ability to silence the horn while allowing the strobes to continue to flash.

Incorporating the control module as shown in the following diagrams, the control module will control the power to the signaling device to produce synchronized operation.

Standard Features

- Synchronize horn and strobe with the use of only two wires
- No limit to the number of modules that can be synchronized together
- Module is rated for 3 amps continuous current and 5 amps surge or inrush current
- Synchronizes to 1 Hz flash rate
- Operates 1 class 'A' circuit or 2 class 'B' circuits at 3 amps per circuit
- Dual synchronization module **ONLY** when using 2 class 'B' circuits
- A green LED status indicator to signal operation of module
- Option to silence the horn while strobes continue to flash when using temporal 3 mode
- Three year warranty from date of purchase

Model Number	Part Number
GTSMR	904-0604-002
GTSMW	904-0539-002

GTSM Series Operating Current (mA)	
Voltage	UL Max
24 VDC (16-33 volts)	45 mA

Notes

- The GTSM module shipped with back box and cover plate
- Dimensions of module: 3.85" (9.78 cm) high x 3.82" (9.70 cm) wide x 1.32" (3.35 cm) deep
- Dimensions of box: 5.57" (14.15 cm) high x 4.55" (11.56 cm) wide x 2.39" (6.07 cm) deep
- A green LED status indicator will flash once every four seconds if zone 1 is operational
- The LED will flash twice every four seconds if zones 1 and 2 are operational
- Strobes should not be used on coded or pulsing signaling circuits

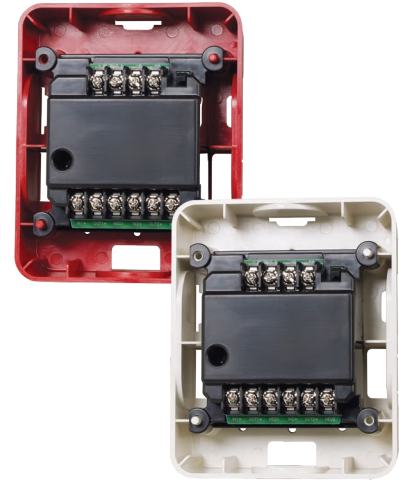

Product Listings



- ANSI/UL 464 and ANSI/UL 1971 Listed
- CAN/ULC S525 and/or CAN/ULC S526 Listed
- CSFM: 7300-0569:0149

Product Compliance

- NFPA 72
- IBC/IFC/IRC
- City & State Ordinances/Laws/Regulations
- Quality Management System is certified to: ISO 9001:2008

Wiring for Multiple CLASS B Circuit and Use of a Slave Module

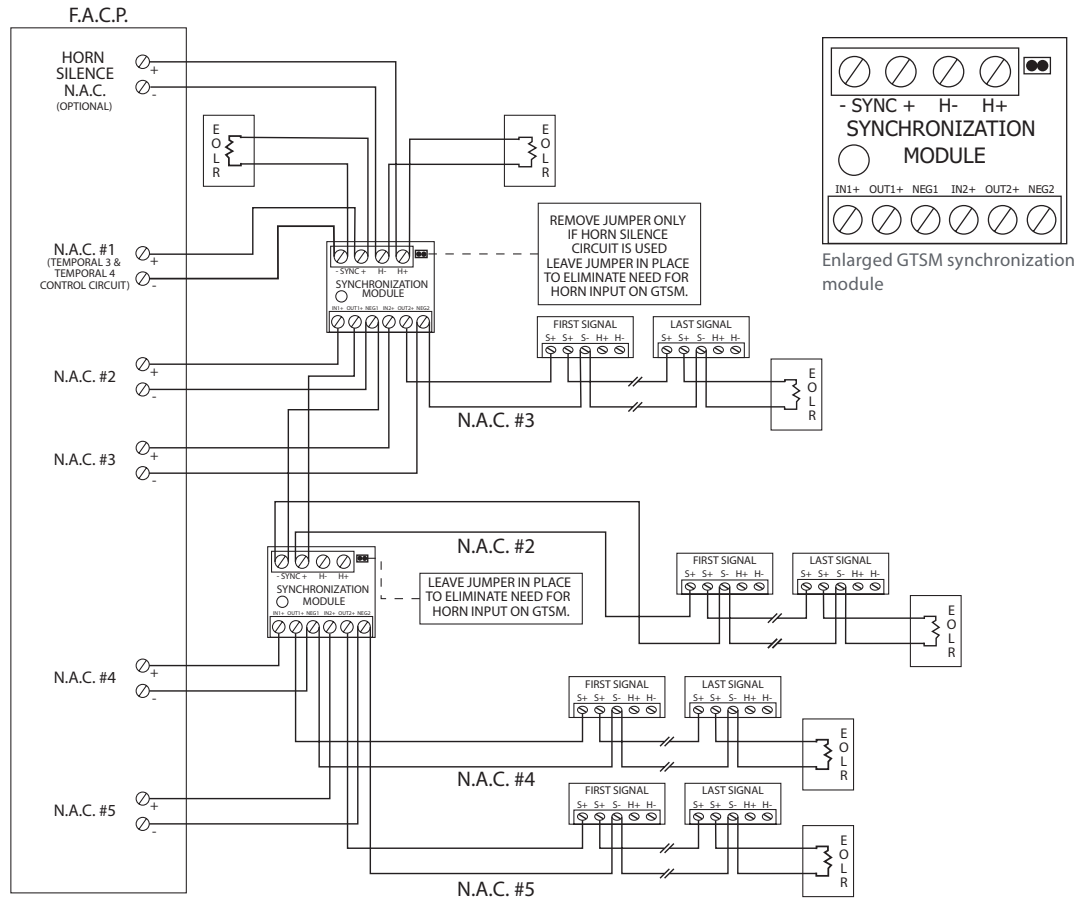

Synchronization Module Sound Output Settings

	NAC 1	NAC 2	NAC 3	NAC 4	NAC 5
Temporal 3	ON	ON	ON	ON	ON
Temporal 4	OFF	ON	ON	ON	ON

Additional GTSM wiring diagrams available on Gentex website: www.gentex.com

Wiring for Synchronized Strobes and Horns

Using this method you may:

- Use only two wires to synchronize the temporal horn and strobe with the ability to mute the horn
- Mute the horn only when the temporal horn option has been selected.
- Use the Gentex synchronization protocol to provide synchronization and mute the horn, if available

Wiring for Synchronized Parallel (Unison) Horn/Strobe Operation

Using this method you may:

- Use four wires where two wires are used to power and synchronize the strobe and two additional wires are used to power and synchronize the horn
- Choose either continuous horn and allow the FACP to control the horn or choose temporal horn and synchronize the horns with the Gentex synchronization protocol
- Use the Gentex synchronization protocol to provide synchronization and mute the horn, if available

Notes

- CROSSING LINES DO NOT INDICATE CONNECTIONS
- The incoming positive power lead must be broken and each lead is to be inserted into each of the top two terminals. If two power runs are made to the signal, one for the strobe and one for the horn, only one of the runs must have its positive lead broken and placed under the two separate top terminals. A barrier is provided to prevent both leads from being placed under the same terminal.
- The GTSM module is listed per ANSI/UL 1971 and CAN/ULC S525 and/or CAN/ULC S526 with a voltage range of 8-33 VDC/FWR. The GTSM module was tested to the stated voltage range(s); do not apply 80% and 110% of this range for system operation. It is for indoor use only, with a temperature range of 0°C - 49°C (32°F - 120°F) and a maximum humidity of 93% humidity.
- **CAUTION:** The GTSM module is to be connected only to circuits that provide continuously applied voltage. Do not use this module on coded or interrupted circuits in which the voltage is cycled on and off.
- A steady DC power is to be applied, without any other protocol (including temporal 3).

Wiring for Multiple CLASS B Circuits and Use of Multiple Slave Modules

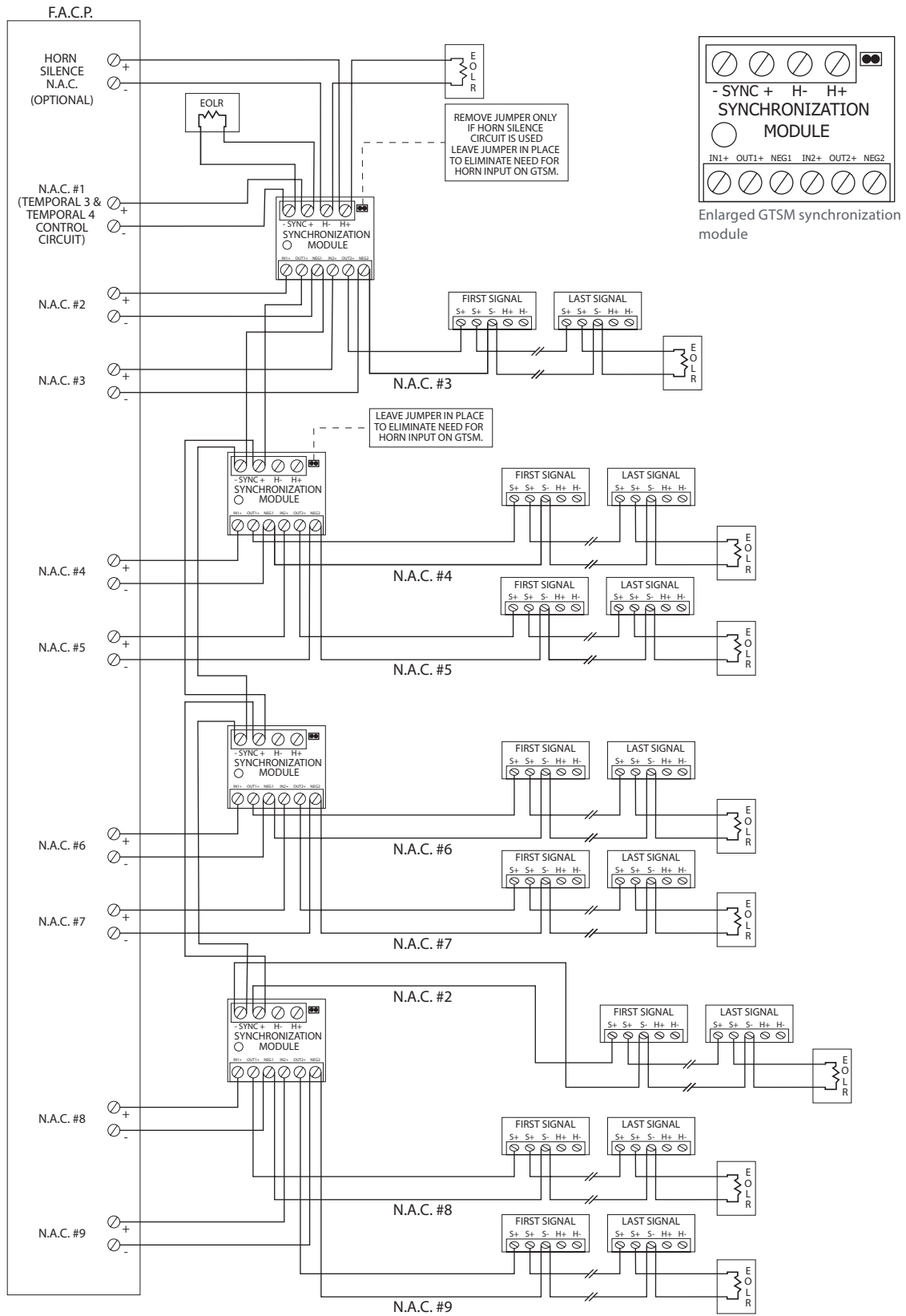

Synchronization Module Sound Settings

	NAC 1	NAC 2	NAC 3	NAC 4	NAC 5
Temporal 3	ON	ON	ON	ON	ON
Temporal 4	OFF	ON	ON	ON	ON

GTSM Control Module

Gangable Synchronization Control Module

Wiring for Multiple CLASS A Circuits and Use of a Slave Module

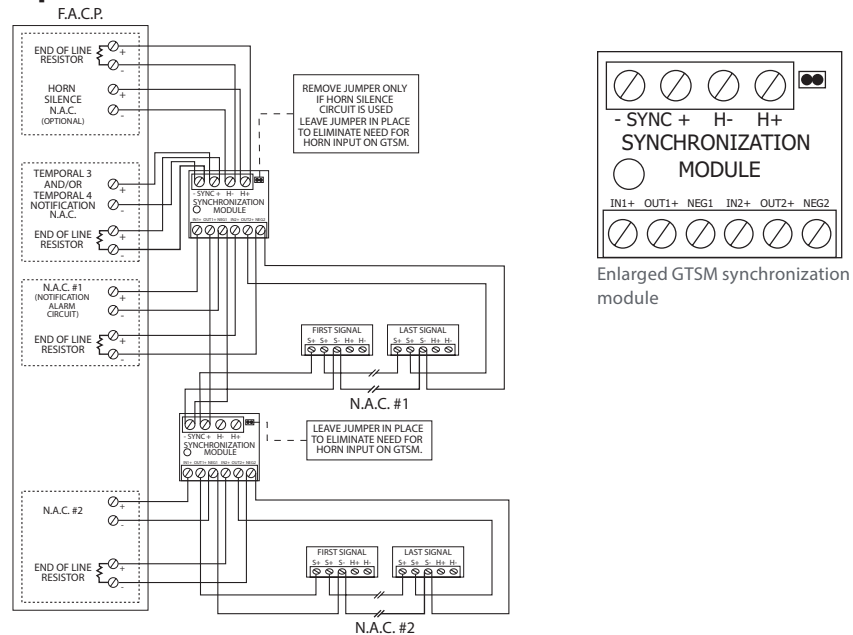

Synchronization Module Sound Output Settings

	NAC 1	NAC 2	NAC 3	NAC 4	NAC 5
Temporal 3	ON	ON	ON	ON	ON
Temporal 4	OFF	ON	ON	ON	ON

Additional GTSM wiring diagrams available on Gentex website: www.gentex.com

Wiring for Synchronized Parallel (unison) Horn/Strobe Operation

Using this method you may:

- Use four wires where two wires are used to power and synchronize the strobe and two additional wires are used to power and synchronize the horn
- Choose either continuous horn and allow the FACP to control the horn or choose temporal horn and synchronize the horns with the Gentex synchronization protocol
- Use the Gentex synchronization protocol to provide synchronization and mute the horn, if available

Wiring for Synchronized Strobes and Horns

Using this method you may:

- Use only two wires to synchronize the temporal horn and strobe with the ability to mute the horn
- Mute the horn only when the temporal horn option has been selected.
- Use the Gentex synchronization protocol to provide synchronization and mute the horn, if available

Notes

- CROSSING LINES DO NOT INDICATE CONNECTIONS
- The incoming positive power lead must be broken and each lead is to be inserted into each of the top two terminals. If two power runs are made to the signal, one for the strobe and one for the horn, only one of the runs must have its positive lead broken and placed under the two separate top terminals. A barrier is provided to prevent both leads from being placed under the same terminal.
- The GTSM module is listed per ANSI/UL 1971 and CAN/ULC S525 and/or CAN/ULC S526 with a voltage range of 8-33 VDC/FWR. The GTSM module was tested to the stated voltage range(s); do not apply 80% and 110% of this range for system operation. It is for indoor use only, with a temperature range of 0°C - 49°C (32°F - 120°F) and a maximum humidity of 93% humidity.
- **CAUTION:** The GTSM module is to be connected only to circuits that provide continuously applied voltage. Do not use this module on coded or interrupted circuits in which the voltage is cycled on and off.
- A steady DC power is to be applied, without any other protocol (including temporal 3).

GENTEX
CORPORATION

Fire Protection Products Group | 10985 Chicago Drive | Zeeland, MI 49464
gentex.com | Phone: 616.392.7195 | Toll-free: 800.436.8391 | Fax: 616.392.4219

GTSM-01

Important Notice: These materials have been prepared by Gentex Corporation ("Gentex") for informational purposes only, are necessarily summary, and are not purported to serve as legal advice and should not be used as such. Gentex makes no representations and warranties, express or implied, that these materials are complete and accurate, up-to-date, or in compliance with all relevant local, state and federal laws, regulations and rules. The materials do not address all legal considerations as there is inevitable uncertainty regarding interpretation of laws, regulations and rules and the application of such laws, regulations and rules to particular fact patterns. Each person's activities can differently affect the obligations that exist under applicable laws, regulations or rules. Therefore, these materials should be used only for informational purposes and should not be used as a substitute for seeking professional legal advice. Gentex will not be responsible for any action or failure to act in reliance upon the information contained in this material. Gentex Corporation reserves the right to make changes to the product data sheet at their discretion.